



# Ranger<sup>®</sup> 2000

Compact Bench Scales



## *The Best Compact Scale in its Class!*

The multipurpose Ranger 2000 has all of the capabilities to produce precise results rapidly for a variety of applications. With seven application modes, Ranger 2000 is the ideal scale to meet many industrial weighing needs. Portable and equipped with a rechargeable battery, this scale is beneficial in every corner of the factory and is equipped with functions and features that elevate the Ranger 2000 to a class of its own.

### *Standard Features Include:*

- **Largest Display in its Class Makes Ranger 2000 Ideal for Use in All Environments**—Ranger 2000 has the largest display in its class and is equipped with checkweighing LED's and red LED displays which makes it functional in almost any working condition.
- **The Most User Friendly Scale on the Market**—Easy setup leads into even easier use—ensuring that your valuable time is not wasted and you're working as proficiently as possible.
- **Rapid Stabilization Provides Unmatched Throughput**—View your results in just one second, and then see your efficiency, throughput and productivity soar!
- **Standard RS232 for Easy Data Transfer**—Ranger 2000 is equipped with standard RS232, making data transfer a simple process.

# Ranger<sup>®</sup>2000 Compact Bench Scale

## Largest Display in its Class

The inviting display makes Ranger 2000 extremely simple to use. The red LED display is 38.1 mm, 57% larger than displays on other comparable products. Checkweighing LED's provide additional confirmation and clarification of results. The bright display makes Ranger 2000 ideal for use in dim settings.

## The Most User Friendly Scale on the Market

Simple menu navigation and dedicated keys make Ranger 2000 the most user-friendly industrial scale on the market. Complete with dedicated TARE key and Yes, No, Back, Exit keys, Ranger 2000 eliminates the need to master complex input commands and allows you to focus on the job at hand.

## Rapid Stabilization

Ranger 2000 produces accurate results within one second. The rapid stabilization virtually eliminates your wait time and allows you to move at a pace determined by you and not your weighing equipment. Work efficiently and with confidence that your results are accurate. Maximize your throughput without sacrificing accuracy with the Ranger 2000.

## Standard RS232 for Easy Data Transfer

Standard RS232 offers a simple way to meet your data transfer needs.

## Portability and Versatile Power Options

Say goodbye to being restricted to working only near power outlets! With its convenient carrying handle and rechargeable lead acid battery that can provide power for more than 110 hours, Ranger 2000 can provide many hours of uninterrupted operation in the area of your workspace that most conveniently fits your needs. It can also be powered through the easy connect power cord that takes up minimal space. Whether you utilize the easy connect power cord or power your scale with its rechargeable battery, you are guaranteed hours of uninterrupted operation.

## Weigh Below Capability Offers Additional Functionality (Option)

The easy-to-use and install weigh below hook offers the functionality to perform specific gravity tests. It can also be used to weigh items that cannot be easily lifted on to the weighing pan.

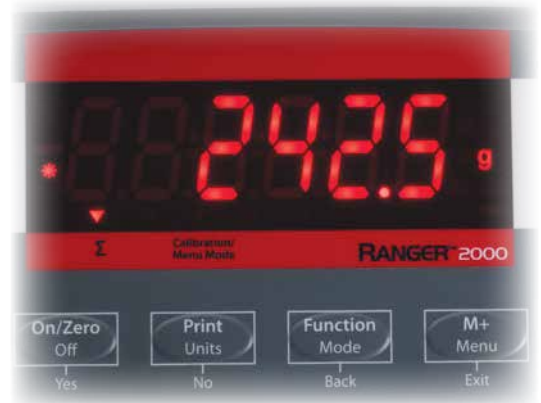

## Application Modes

- **Weighing**—Determine the weight of items in the selected unit of measure.
- **Percent Weighing**—Measure the weight of a sample displayed as a percentage of a pre-established Reference Weight.
- **Parts Counting**—Count samples of uniform weight.
- **Check Weighing/Percent/Counting**—Compare the weight/percent/count of a sample against target limits. Choose from Checkweight, Checkpercent or Checkcount.
- **Accumulation**—Totalization of weight, count or percent. Calculates total accumulated weight, count, or percent of separate items.
- **Dynamic Weighing**—Weigh an unstable load. Balance takes an average of weights over a time period.
- **Display Hold**—Manually or automatically holds the last stable weight on the balance display. Activated by setting time interval of Dynamic Weighing to zero.

## Outline Dimensions

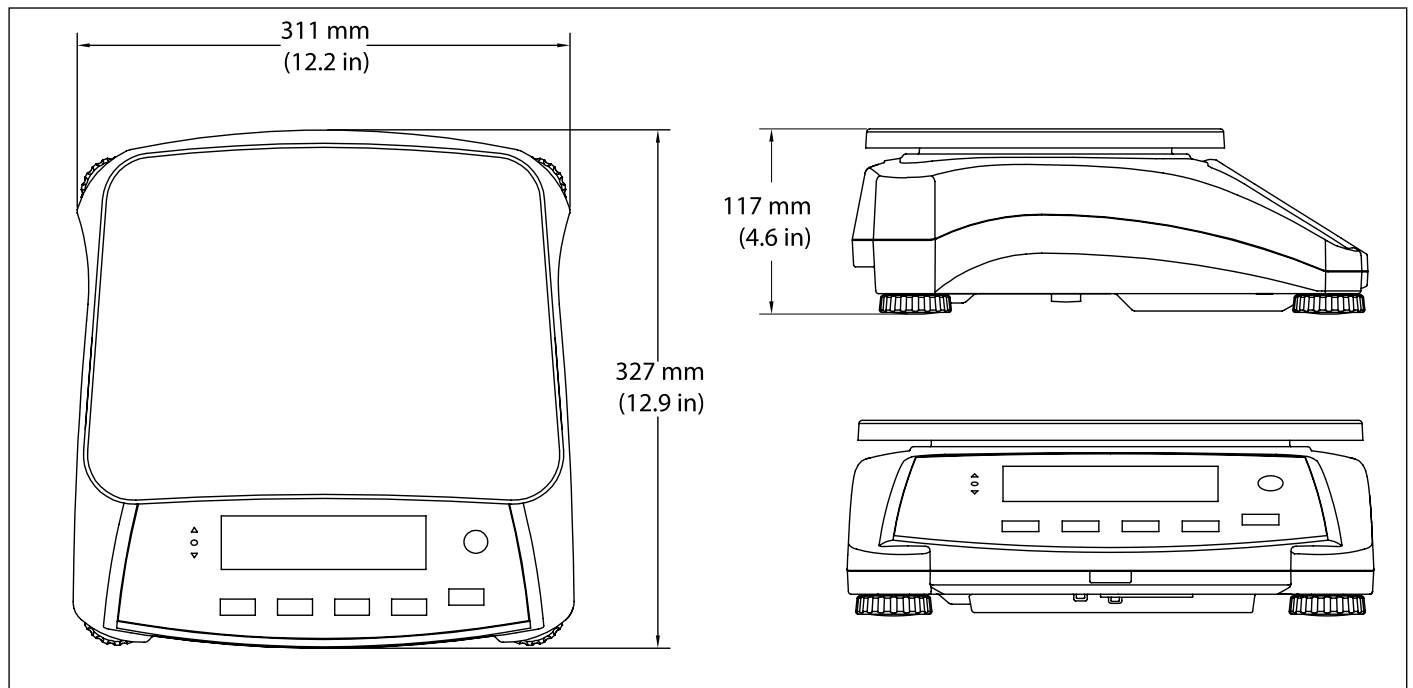

# Ranger® 2000 Compact Bench Scale

Model	R21PE1502	R21PE3	R21PE6	R21PE15	R21PE30	R21PHE15
Default Capacity × Readability	1.5 kg × 0.00005 kg 1500 g × 0.05 g	3 kg × 0.0001 kg 3000 g × 0.1 g	6 kg × 0.0002 kg 6000 g × 0.2 g	15 kg × 0.0005 kg 15000 g × 0.5 g	30 kg × 0.001 kg 30000 g × 1 g	15kg x 0.0001kg 15000 g × 0.1 g
Maximum Displayed Resolution	1:30000	1:30000	1:30000	1:30000	1:30000	1:300000
Construction	Plastic pan with Stainless steel cover, ABS plastic housing					
Weighing units	kg, g, lb, oz, lb:oz					
Application Modes	Weighing, Parts Counting, Checkweighing, Checkcounting, Checkpercent, Percent Weighing, Dynamic/Display Hold, Accumulation					
Display	40 mm high Red LED display, 6-digit, 7-segment					
Checkweighing Indicators	3 LED (yellow, green, red) with configurable operation and alert beeper					
Keypad	5 mechanical keys					
Zero Range	4% or 20% of full scale capacity					
Tare Range	Full capacity by subtraction					
Stabilization time	1 second					
Auto-Zero Tracking	Off, 0.5, 1 or 3 divisions					
Safe Overload Capacity	150% of capacity					
Power	220-240 VAC / 50-60 Hz internal transformer, internal rechargeable lead acid battery					
Battery Life	110 hours continuous use with 12 hour recharge time					
Calibration	External, with user-selectable calibration weight					
Interface	Built-in RS232					
Operating Temperature Range	-10° C to 40° C					
Pan Size (W × L)	300 × 225 mm					
Scale Dimensions (W × L × H)	311 × 327 × 117 mm					
Shipping Dimensions (W × L × H)	397 × 447 × 195 mm					
Net Weight	3.9 kg					
Shipping Weight	5.15 kg					

## Other Standard Features and Equipment

Transportation handle, sealed front panel, menu lockswitch, up front level indicator, adjustable leveling feet, selectable environmental and auto-print settings, stability indicator, overload and underload indicators, low battery indicator, auto shut-off, auto tare

## Accessories

<b>Weigh Below Hook</b> .....	30037450
<b>In Use Cover</b> .....	30037451
<b>Stainless Steel Platform</b> .....	30037452
<b>SF40A Impact Printer</b> .....	30045641

**OHAUS Europe GmbH** Im  
Langacher 44  
8606 Greifensee  
Switzerland

e-mail: [ssc@ohaus.com](mailto:ssc@ohaus.com)  
Tel: 0041 22 567 53 19  
e-mail: [tsc@ohaus.com](mailto:tsc@ohaus.com)  
Tel: 0041 22 567 53 20

**www.ohaus.com**  
OHAUS Corporation is an ISO  
9001:2008 manufacturer

**ISO 9001:2008**  
Registered Quality  
Management System

